



Model: All Serial #: N/A	May 28, 2020
Product Bulletin # TDS-219 v 1.0	

Handler Rotate Pinion Guard Upgrade

Canrig has created a new handler rotate pinion guard with a longer pinion retainer bolt that reduces the risk of a dropped object from the pinion retainer bolt.

Affected Units

All Canrig top drives.

Recommendation

Inspect the top drive handler rotate assembly for the updated handler rotate pinion guard. See below for the old style guard compared to the new style guard.



Figure 1: Old Style Guard



Figure 2: New Style Guard



Note: If your top drive currently has the new style guard, please disregard this product bulletin.

If your top drive has the old guard installed, please contact RIGLINE 24/7™ to order the new guard. Install the guard and longer pinion retainer bolt on the handler rotate assembly using the field installation kit, see Table 1 on page 2 and Figure 3 on Page 2.

Table 1: Guard Upgrade Kit Options

Top Drive Load Rating	Upgrade Kit Part #	Upgrade Kit Description
175 Ton	AY24528-175	Kit, Rotary Manifold, Guard, 175T
275 Ton	AY24528-275	Kit, Rotary Manifold, Guard, 275T
350 Ton	AY24528-350	Kit, Rotary Manifold, Guard, 350T
500 Ton	AY24528-500	Kit, Rotary Manifold, Guard, 500T/750T
750 Ton	AY24528-500	Kit, Rotary Manifold, Guard, 500T/750T

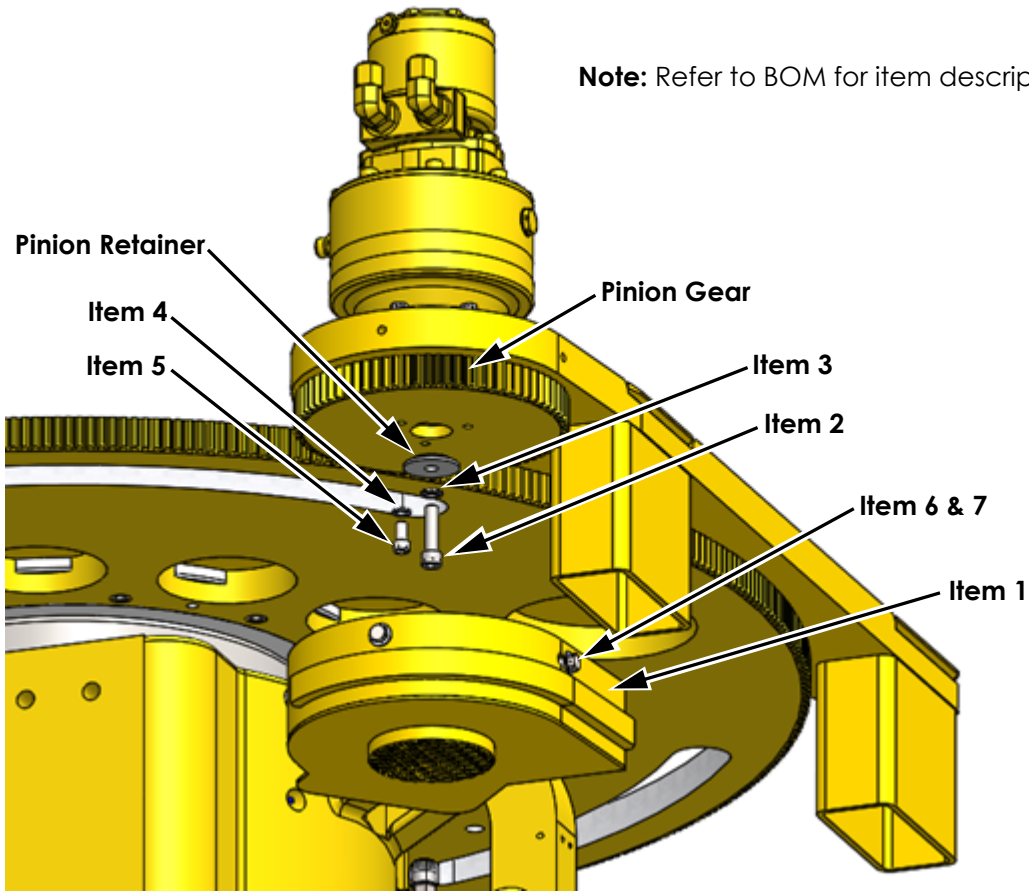

Figure 3: Guard Upgrade Kit Installation