



CANRIG DRILLING TECHNOLOGY LTD

PRODUCT BULLETIN NUMBER: 31

DATE: May 13, 1994

SUBJECT: Top Drive - Mast Guide Rails

SERIAL NUMBERS: 005, 006, 010, 011, 012

DISCUSSION: To achieve proper life on the top drive guide runners, the mast guide rail must have smooth transitions between sections.

RECOMMENDATION:

1. All transitions of the guide rails between mast sections should be examined. Sharp edges or mis-aligned rails will damage the urethane coating of the top drive guide runners.
2. All transitions should be prepared with tapers in accordance with the attached drawing.

INFORMATION:

For further information contact:

Field Operations Manager
Canrig Drilling Technology Ltd.
14703 FM 1488
Magnolia, Texas 77354
Phone: 281.259.8887
Fax: 281.259.8158

CANRIG DRILLING TECHNOLOGY

PRODUCT BULLETIN No. 31

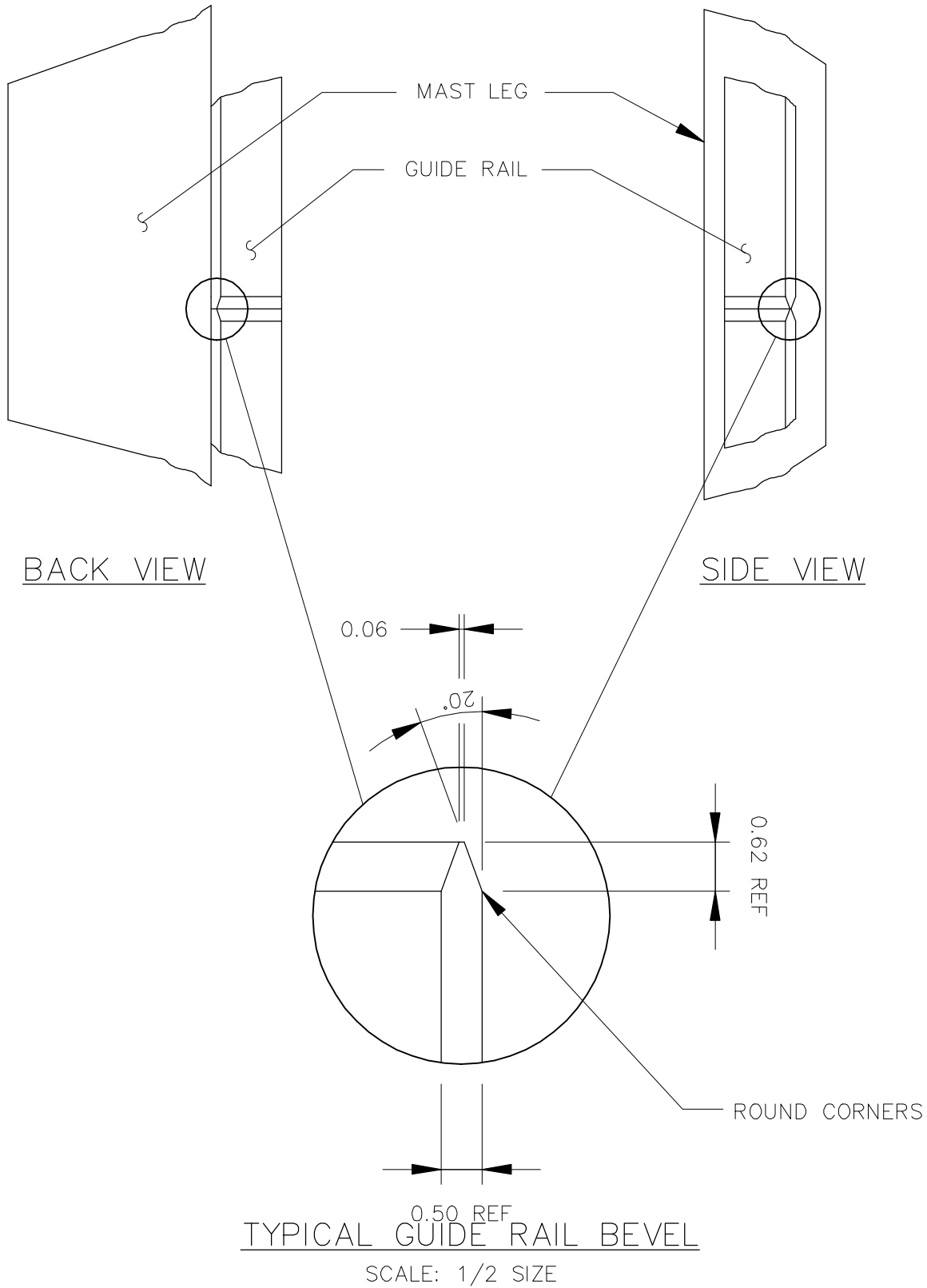

DRAWING NO.	PB-031	DRAWN BY	MPM	SCALE	1/8 SIZE
REV.	0	DATE	94/05/06	PLOTTED	94/05/09