



Model: Sigma

Serial #: N/A

Oct. 30, 2024

Product Bulletin # TDS-259 Rev 1

Sigma Low Lube Sensor Inspection

Issue

When operating the Sigma model top drive at a high speed or above 120 rpm, there is a reduction in the flow of the lube oil through the main housing and down to the reservoir due to centrifugal force while rotating and due to additional restrictions in bearing clearances. This condition worsens when the temperature is cooler due to the increase in viscosity of the lube oil and can cause a low oil level sensor and/or low pressure alarm.

Recommendation

- Low temperatures can cause the lube oil viscosity to increase, reducing the flow rate of the lube oil through the main housing upper/lower bearings and down through the oil pan to the reservoir. Ensure heaters are activated in this condition to help reduce the lube oil viscosity for better flow. Arctic grade oil should also be used in low temperature conditions to improve the flow rate.

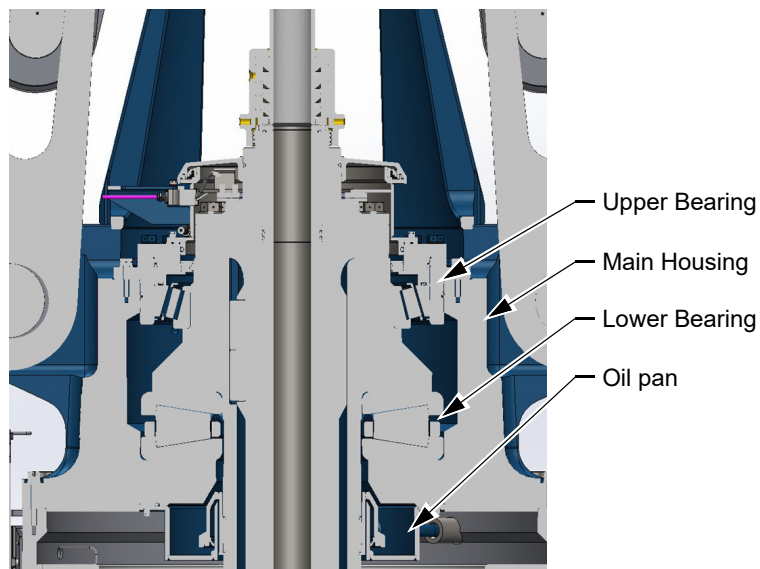

Figure 1: Main housing, bearings, and oil pan



Model: Sigma

Serial #: N/A

Oct. 30, 2024

1. Inspect the two high and low sight-glasses in the reservoir shown in Figure 2 to ensure the level of oil is not below the lower sight glass level limit.

NOTICE

The reservoir on the Sigma top drive is intended to operate with a high level of lube oil to prevent cavitation of the lube pump.

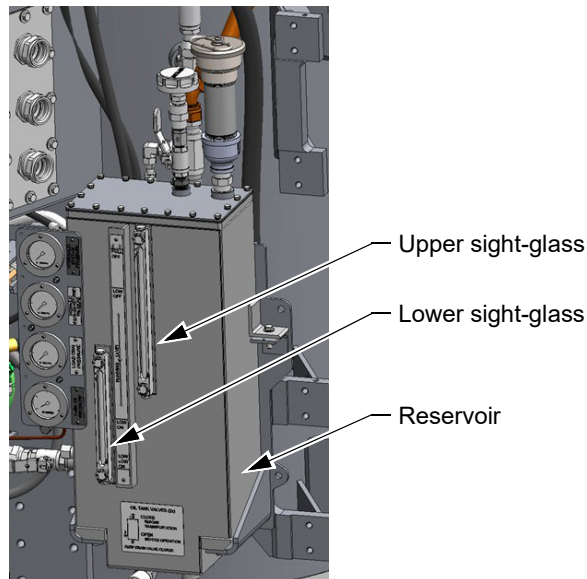

Figure 2: Sight-glasses and reservoir

2. Inspect the lube oil filter shown in Figure 3 to ensure the filter is not clogged.

NOTICE

If the pressure after the filter is low, this may indicate the filter is clogged and prevent distribution of lube oil into the entire lube system. The program code issues a low pressure alarm at 10 psi and another lower pressure alarm at 5 psi which the system shuts down 10 minutes after the lower pressure alarm is triggered.

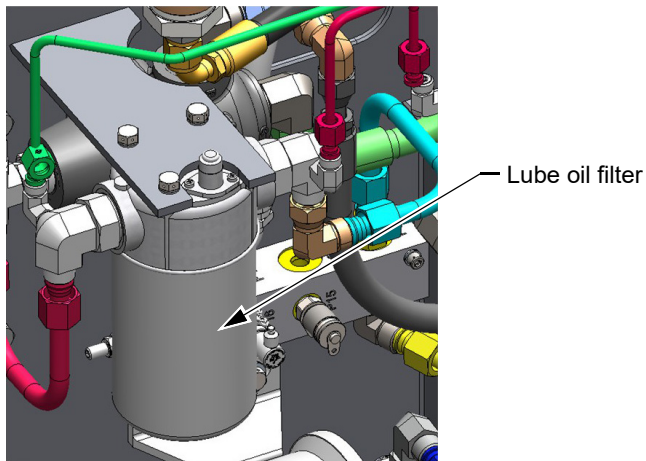

Figure 3: Lube oil filter



Model: Sigma

Serial #: N/A

Oct. 30, 2024

3. Inspect the filler cap on the reservoir shown in Figure 4 to ensure the cap is tightly fastened, installed properly, and not drawing in air.

NOTICE

The reservoir can intake air if the reservoir is not sealed properly.

4. Inspect the reservoir breather shown in Figure 4 and check the valve for damage or inoperability.

NOTICE

The reservoir breather should allow the pressure to escape when the oil temperature increases, but also is intended to prevent the intake of air from the atmosphere. Clean or replace the reservoir breather if air is being drawn into the reservoir.

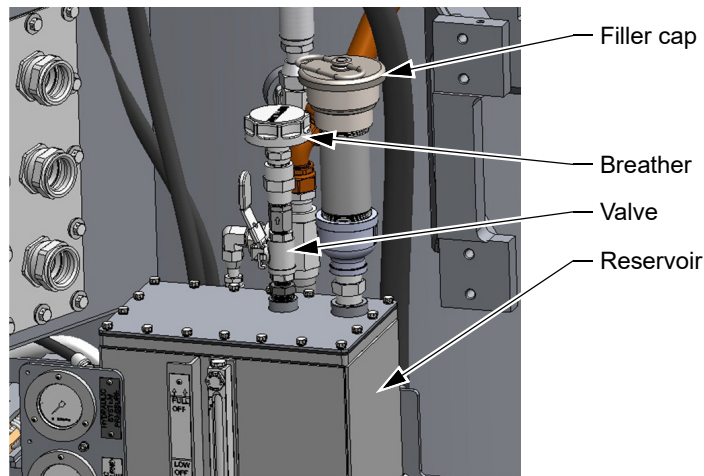

Figure 4: Reservoir filler cap, breather and valve

5. Inspect the lube oil plumbing to ensure all of the hose and tubing connections are secured and undamaged.